

Becoming a Competent Leader (CL)

Complete requirements for the new Competent Leadership Award can be found in the new CL Manual (Catalog #265).

The following table shows what meeting or club roles fulfill project requirements in the Competent Leadership manual.

Only projects completed after January 1, 2006 may be counted. Keep this matrix in your CL manual and fill in circles as you complete each meeting role. Each role counts only once.

Meeting Role	Project									
	1	2	3	4	5	6	7	8	9	0
<input type="radio"/> Speaker				<input type="radio"/>	<input type="radio"/>					
<input type="radio"/> Speech Evaluator	<input type="radio"/>	<input type="radio"/>	<input type="radio"/>					<input type="radio"/>		
<input type="radio"/> Timer				<input type="radio"/>						
<input type="radio"/> Grammarian	<input type="radio"/>	<input type="radio"/>	<input type="radio"/>	<input type="radio"/>						
<input type="radio"/> Ah-Counter	<input type="radio"/>									
<input type="radio"/> Table Topics Speaker	<input type="radio"/>									
<input type="radio"/> Table Topicsmaster				<input type="radio"/>	<input type="radio"/>		<input type="radio"/>			
<input type="radio"/> General Evaluator		<input type="radio"/>	<input type="radio"/>		<input type="radio"/>		<input type="radio"/>	<input type="radio"/>		<input type="radio"/>
<input type="radio"/> Toastmaster				<input type="radio"/>	<input type="radio"/>		<input type="radio"/>	<input type="radio"/>		<input type="radio"/>
<input type="radio"/> Help Organize Club Speech Contest						<input type="radio"/>				
<input type="radio"/> Chair a Club Speech Contest									<input type="radio"/>	
<input type="radio"/> Help Organize a Club Special Event						<input type="radio"/>				
<input type="radio"/> Chair a Club Special Event									<input type="radio"/>	
<input type="radio"/> Help Organize a PR Campaign						<input type="radio"/>				
<input type="radio"/> Chair: Membership Contest/Campaign						<input type="radio"/>				
<input type="radio"/> Membership Campaign or Contest						<input type="radio"/>		<input type="radio"/>		<input type="radio"/>
<input type="radio"/> Help Produce a Club Newsletter						<input type="radio"/>				
<input type="radio"/> Assist a Club Webmaster						<input type="radio"/>				
<input type="radio"/> Club N/L Editor or Webmaster										<input type="radio"/>
<input type="radio"/> Befriend a Guest							<input type="radio"/>			
<input type="radio"/> Mentor a New Member										<input type="radio"/>
<input type="radio"/> Mentor an Existing Member										<input type="radio"/>
<input type="radio"/> Guidance Committee Member										<input type="radio"/>

Learn leadership by serving in positions where you can practice them. Actively participate in your club, and you will become a purposeful and confident leader.

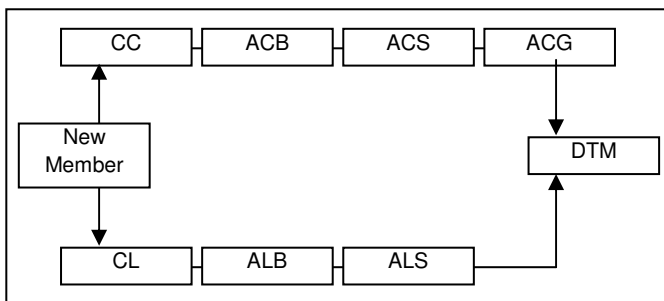

Visit the the D82 Website
<http://www.t82.org/GoalCards.htm>
 and download your own personal copy of this GoalCard.



Comments, corrections, suggestions
 Contact: Frank Storey, DTM
frank@designsbyfrank.com

Becoming a Competent Leader (CL)

Complete requirements for the new Competent Leadership Award can be found in the new CL Manual (Catalog #265).

The following table shows what meeting or club roles fulfill project requirements in the Competent Leadership manual.

Only projects completed after January 1, 2006 may be counted. Keep this matrix in your CL manual and fill in circles as you complete each meeting role. Each role counts only once.

Meeting Role	Project									
	1	2	3	4	5	6	7	8	9	0
<input type="radio"/> Speaker				<input type="radio"/>	<input type="radio"/>					
<input type="radio"/> Speech Evaluator	<input type="radio"/>	<input type="radio"/>	<input type="radio"/>					<input type="radio"/>		
<input type="radio"/> Timer				<input type="radio"/>						
<input type="radio"/> Grammarian	<input type="radio"/>	<input type="radio"/>	<input type="radio"/>	<input type="radio"/>						
<input type="radio"/> Ah-Counter	<input type="radio"/>									
<input type="radio"/> Table Topics Speaker	<input type="radio"/>									
<input type="radio"/> Table Topicsmaster				<input type="radio"/>	<input type="radio"/>		<input type="radio"/>			
<input type="radio"/> General Evaluator		<input type="radio"/>	<input type="radio"/>		<input type="radio"/>		<input type="radio"/>	<input type="radio"/>		<input type="radio"/>
<input type="radio"/> Toastmaster				<input type="radio"/>	<input type="radio"/>		<input type="radio"/>	<input type="radio"/>		<input type="radio"/>
<input type="radio"/> Help Organize Club Speech Contest						<input type="radio"/>				
<input type="radio"/> Chair a Club Speech Contest									<input type="radio"/>	
<input type="radio"/> Help Organize a Club Special Event						<input type="radio"/>				
<input type="radio"/> Chair a Club Special Event									<input type="radio"/>	
<input type="radio"/> Help Organize a PR Campaign						<input type="radio"/>				
<input type="radio"/> Chair: Membership Contest/Campaign						<input type="radio"/>				
<input type="radio"/> Membership Campaign or Contest						<input type="radio"/>		<input type="radio"/>		<input type="radio"/>
<input type="radio"/> Help Produce a Club Newsletter						<input type="radio"/>				
<input type="radio"/> Assist a Club Webmaster						<input type="radio"/>				
<input type="radio"/> Club N/L Editor or Webmaster										<input type="radio"/>
<input type="radio"/> Befriend a Guest							<input type="radio"/>			
<input type="radio"/> Mentor a New Member										<input type="radio"/>
<input type="radio"/> Mentor an Existing Member										<input type="radio"/>
<input type="radio"/> Guidance Committee Member										<input type="radio"/>

Learn leadership by serving in positions where you can practice them. Actively participate in your club, and you will become a purposeful and confident leader.

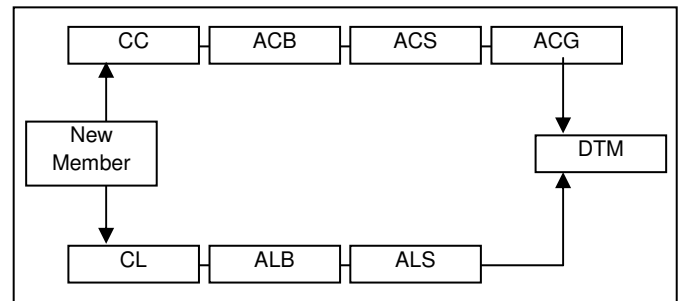

Visit the the D82 Website
<http://www.t82.org/GoalCards.htm>
 and download your own personal copy of this GoalCard.



Comments, corrections, suggestions
 Contact: Frank Storey, DTM
frank@designsbyfrank.com