

Becoming a Competent Leader (CL)

Complete requirements for the new Competent Leadership Award can be found in the new CL Manual (Catalog #265).

The following table shows what meeting or club roles fulfill project requirements in the Competent Leadership manual.

Only projects completed after January 1, 2006 may be counted. Keep this matrix in your CL manual and fill in circles as you complete each meeting role. Each role counts only once.

Meeting Role	Project									
	1	2	3	4	5	6	7	8	9	0
Speaker					○	○				
Speech Evaluator	○	○	○					○		
Timer				Ⓜ						
Grammarian	○	○	○	○						
Ah-Counter	○									
Table Topics Speaker	○									
Table Topicsmaster				○	○		○			
General Evaluator		○	○		○		○	○	○	
Toastmaster				○	○		○	○	○	
Help Organize Club Speech Contest						○				
Chair a Club Speech Contest										Ⓜ
Help Organize a Club Special Event						○				
Chair a Club Special Event										Ⓜ
Help Organize a Public Relations Campaign						○				
Chair a Public Relations Campaign						○		Ⓜ	Ⓜ	
Help Organize Membership Campaign or Contest						○		○	○	
Chair a Club Membership Campaign or Contest								Ⓜ	Ⓜ	Ⓜ
Assist a Club Webmaster					○					
Serve as Club N/L Editor or Webmaster										○
Befriend a Guest at a Club Meeting							○			
Mentor a New Member									○	
Mentor an Existing Member									○	
Guidance Committee Member									○	
Help Produce a Club Newsletter					○					

- Ⓜ Must be timer, and then any one of four roles listed
- Ⓜ Must serve three roles, and at least one must be as Chair of Club Membership Contest or Chairman of a Club Pr Campaign
- Ⓜ Serve as Toastmaster and General Evaluator, OR one of the 3 indicated by Ⓜ

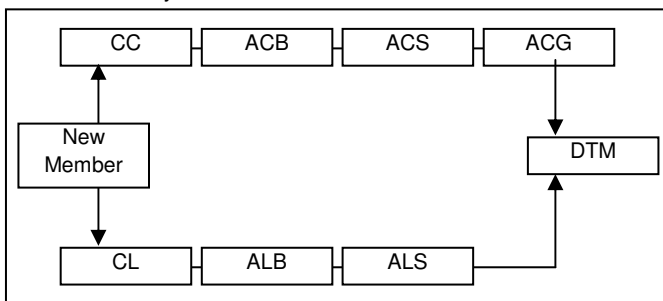

Visit the Gaveliers TM Club website at <http://gavelierstoastmasters.com/GoalCards.htm> and to get your own copy of this GoalCard.



Comments, corrections, suggestions
Contact: Frank Storey, DTM
frankstorey@cablespeed.com

Becoming a Competent Leader (CL)

Complete requirements for the new Competent Leadership Award can be found in the new CL Manual (Catalog #265).

The following table shows what meeting or club roles fulfill project requirements in the Competent Leadership manual.

Only projects completed after January 1, 2006 may be counted. Keep this matrix in your CL manual and fill in circles as you complete each meeting role. Each role counts only once.

Meeting Role	Project									
	1	2	3	4	5	6	7	8	9	0
Speaker					○	○				
Speech Evaluator	○	○	○					○		
Timer				Ⓜ						
Grammarian	○	○	○	○						
Ah-Counter	○									
Table Topics Speaker	○									
Table Topicsmaster				○	○		○			
General Evaluator		○	○		○		○	○	○	
Toastmaster				○	○		○	○	○	
Help Organize Club Speech Contest						○				
Chair a Club Speech Contest										Ⓜ
Help Organize a Club Special Event						○				
Chair a Club Special Event										Ⓜ
Help Organize a Public Relations Campaign						○				
Chair a Public Relations Campaign						○		Ⓜ	Ⓜ	
Help Organize Membership Campaign or Contest						○		○	○	
Chair a Club Membership Campaign or Contest								Ⓜ	Ⓜ	Ⓜ
Assist a Club Webmaster					○					
Serve as Club N/L Editor or Webmaster										○
Befriend a Guest at a Club Meeting							○			
Mentor a New Member									○	
Mentor an Existing Member									○	
Guidance Committee Member									○	
Help Produce a Club Newsletter					○					

- Ⓜ Must be timer, and then any one of four roles listed
- Ⓜ Must serve three roles, and at least one must be as Chair of Club Membership Contest or Chairman of a Club Pr Campaign
- Ⓜ Serve as Toastmaster and General Evaluator, OR one of the 3 indicated by Ⓜ

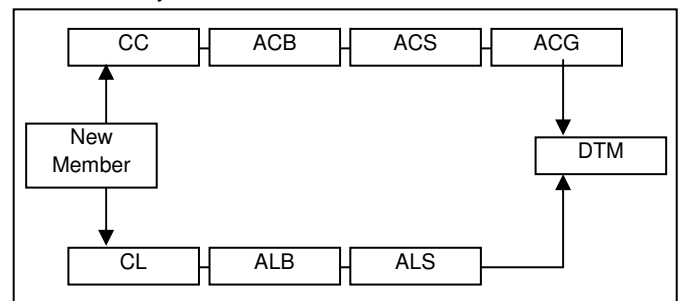

Visit the Gaveliers TM Club website at <http://gavelierstoastmasters.com/GoalCards.htm> and to get your own copy of this GoalCard.



Comments, corrections, suggestions
Contact: Frank Storey, DTM
frankstorey@cablespeed.com